

Original Research Article

<https://doi.org/10.20546/ijcmas.2019.805.226>

Assessing Suitability of Fluted Roller Metering Mechanism for Cassava Setts Planter

M. Dinesh Pandi^{1*}, D. Asokan², J. John Gunasekar² and S. Vallal Kannan²

¹Department of Farm Machinery and Bio-Energy, ²AEC & RI, Kumulur, Trichy-621 712, India

*Corresponding author

ABSTRACT

Keywords

Cassava planting, Cassava sett, Fluted roller metering mechanism, Filling efficiency

Article Info

Accepted:
17 April 2019
Available Online:
10 May 2019

Manual planting of Cassava is time-consuming, unpleasant arduous job and demands a large quantity of human labour. Labor shortage is one of the major constraints in manual cassava planting in India, especially in Tamil Nadu. Study was conducted to meter the cassava setts using a fluted roller metering mechanism. A laboratory model of fluted roller metering mechanism was developed and its metering filling efficiency was evaluated. The study was carried out to design the optimum cell size at different peripheral speed on filling efficiency. The levels of speed selected for the laboratory tests were taken as 0.13, 0.20, 0.26, 0.33, 0.40, 0.46, 0.52, 0.59, 0.65 and 0.72 m/s. The results revealed that when the peripheral speed exceeds 0.33 m/s, the filling efficiency begin to drop substantially for both the size (38.5 and 42.5 mm) of cell. The maximum filling efficiency of 58 % was obtained at the peripheral speed of 0.33 m/s with the cell size of 42.50 mm.

Introduction

Cassava (*Manihot esculenta*) is the most widely cultivated root crop in tropics and is grown across a broad range of agro-climatic conditions. It is native of South America and basic food for millions of people around the world. It is a shrubby perennial with stems that reaches to the height of 274 cm and above. The starch produced from the roots of cassava is commonly used as a food thickener and best known ingredient in tapioca pudding and many more industrial uses. In India, the cultivation of cassava is mainly done at

Kerala, Tamil Nadu, Andhra Pradesh, Meghalaya and Assam, among these states Tamil Nadu stands first both in area and production of cassava followed by Kerala and Andhra Pradesh (Varmudy, 2014).

Manual planting is an expensive and time-consuming operation, and hence the timely planting is affected due to non-availability of labours, delaying in planting affects both quantity and quality of the tubers. However, farmers are looking forward to have an appropriate technology to plant cassava in time at low cost at affordable rate. The

objective of this study is to check the suitability of fluted roller metering mechanism for cassava planting, as it is an easy and less maintenance one. The fluted roller metering mechanism was studied at different cell size and speed. Ryu and Kim (1998) developed a method to design the roller-type metering device for hill dropping planters. The same metering mechanism was modified and constructed for sowing oilseed rape (Ahmadi *et al.*, 2007). Muhammad Farooq (1992) developed finger wheel mechanism for sowing the sugarcane setts.

Materials and Methods

Design of fluted roller mechanism for cassava sett

The shape and size of cell are the important parameters for designing fluted roller mechanism. The size of cell is determined based on size of setts and number of setts to be dropped per hill. Since one sett per hill is the planting procedure for cassava. Odigboh (1978) reported that receptacle shape of cell is important for the design of fluted roller to meter the cassava setts.

In this study, receptacle shape of two sizes of cell were taken as 10 percent and 25 percent more than the maximum sett dimension of single cassava sett (Table 1) by using ruling varieties in Tamil Nadu viz., Yethapur local, Srivijaya, Co4 and Cucumarose. The diameter of cells was fixed as 38.5 mm and 42.5 mm respectively (Table 2) and depth of groove (d_g) was maintained as 40 mm for both the cells. Normally cassava sett is planted with an average length of 150 mm and hence, the length of grooves was fixed as 160 mm with 10 mm as allowance and welded over the surface of a cylinder at 180° interval for taken for this study. Number of grooves in the metering drum was taken as four and each pair of grooves (a' and b') was fixed in opposite direction at 180° interval. Ryu and

Kim (1998) studied repose angle and friction angle for designing the left and right groove angle of the cell. The repose angle was determined for all the above mentioned varieties and the value was arrived as 36.5° . The friction angle was selected as 31° which is calculated from co-efficient of static friction between cassava setts and mild steel material (Pandi *et al.*, 2017). The left side angle of the groove was selected as 81° to decrease the time delay as much as possible between the setts consecutively dropped from the grooves. The right side angle of the groove was selected as 30° to give easy access to the setts into the groove. The open angle of the groove opening was $\theta_g = 26^\circ$. Orthographic and isometric view of the fluted roller metering device selected is shown in figure 1.

Construction of fluted roller metering mechanism test rig

The components of cassava metering test rig includes mainframe, cassava sett metering roller, shaft, motor, feeding hopper, foam roller, cam, pulley, belts and bearings (Fig. 2). The main frame is a rectangular section of 920×620 mm fixed at a height of 763 mm from ground level. Variable speed motor and sett metering disc were fitted on the sub frame. The hopper was designed to hold 200 pieces of cassava setts with an average diameter of 35 mm. Both sides of the hopper were covered by acrylic sheet to observe the movement of sett in the metering disc as shown in figure 3. A foam roller was provided to singulate cassava setts and to fit in the cell properly. A cam mechanism was provided to the bottom of feed trough to vibrate the setts. The feed trough was hinged to the middle of the hopper and to permit one or few near the metering disc. A variable speed drive operated by a 0.5 kW electric motor was mounted on the sub frame. The motor speed was reduced from 1,500 rpm to the required level of 10 to 55 rpm.

Experimental procedure for laboratory testing

Cassava setts having the diameter in the range of 30 to 35 mm gave better results in germination and sett length of 150 mm was taken for conducting laboratory trails. The hopper was filled with cassava setts and the metering drum was driven at different speeds. For each experimental run the number of setts discharged was noted with respect to time. While studying the metering efficiency of 38.5 mm cells size the other two bigger cells of size 42.5mm were kept closed.

Similarly while using the 42.5mm cells the other two 38.5mm cells were kept closed. The metering efficiency of each cell was evaluated based on filling efficiency (equation 1) which is calculated based on the actual number of setts delivered comparing with the number setts expected based on design (Odigboh, 1978).

$$F.E.=C_a/C_e*100 \dots\dots\dots (1)$$

C_a =Actual number of setts delivered
 C_e =Number of setts expected design

Results and Discussion

The effect of speed and size of the cell on filling efficiency of the metering roller at different speeds are presented in Table 1 and

2. The maximum filling efficiencies obtained in cell sizes of 38.50 and 42.50 mm were recorded as 48 and 58 % respectively at 20 rev/min. While increasing the peripheral speed above 20 rev/min it is recorded that there is a drop in filling efficiency substantially. Odigboh (1978) also reported that drop in filling efficiency by increasing the peripheral speed.

The result revealed that 42.50 mm cell size has higher filling efficiency than the 38.5 mm cell size. This may be due to the increase in cell size gave better entry to the setts compared to 38.5 mm cell size. The filling efficiency was higher at the medium peripheral speed of metering drum at 0.26 m/s for both the sizes of the cells compared to the low (0.13 m/s) and high peripheral speed of metering drum (0.7 m/s). In the low peripheral speed of metering drum (0.13 m/s), cassava picking time between the flute and sett was high.

Hence, the flute tries to pick two cassava setts at one entry and two setts complete to fill the flute, which results in failure to fill the cassava sett in the flute. Whereas at higher peripheral speed, the available picking time by each flute to accommodate the sett was reduced, resulting in failure to pick up the sett and hence the filling efficiency got reduced significantly (Fig. 4).

Table.1 Cassava stem diameter (mm) of different varieties commonly cultivated in Tamil Nadu

Diameter	Yethapur	Srivijaya	CO ₄	Cumcumarose
Minimum(mm)	31	30	27	30
Maximum(mm)	35	34	35	35

Table.2 Diameter (mm) of fluted roller type cells selected

Sl. No.	Maximum sett dimension (mm)	10 percent more than maximum sett dimension (a') (mm)	25 percent more than maximum sett dimension (b') (mm)
1	35 mm	38.5 mm	42.5 mm

Table.3 Filling efficiency at various peripheral speeds for cell size 38.50mm (having 10 per cent more than the maximum sett dimensions)

Duration of run,t (min)	Metering drum rev/min (N)	Peripheral speed of metering drum $V=\Pi \times D \times N/60$ m/s	Number of setts expected to be metered $c_e=2Nt$	Actual number of setts metered c_a			Average Filling efficiency $(c_a/c_e) \times 100$ (%)
				R ₁	R ₂	R ₃	
1	10	0.13	20	6	10	8	40
1	15	0.20	30	14	12	15	45
1	20	0.26	40	18	20	19	48
1	25	0.33	50	21	22	20	42
1	30	0.39	60	21	23	22	37
1	35	0.46	70	26	25	27	37
1	40	0.52	80	26	28	27	34
1	45	0.59	90	25	25	25	28
1	50	0.65	100	23	24	22	23
1	55	0.72	110	20	22	21	19

Table.4 Filling efficiency at various peripheral speeds for cell size 42.50mm (having 25 per cent more than the maximum sett dimensions)

Duration of run,t (min)	Metering drum rev/min (N)	Peripheral speed of metering drum $V=\Pi \times D \times N/60$ m/s	Number of setts expected to be metered $c_e=2Nt$	Actual number of setts metered c_a			Average Filling efficiency $(c_a/c_e) \times 100$ (%)
				R ₁	R ₂	R ₃	
1	10	0.13	20	10	10	9	50
1	15	0.20	30	18	16	15	53
1	20	0.26	40	23	22	24	58
1	25	0.33	50	28	27	29	56
1	30	0.39	60	32	34	33	55
1	35	0.46	70	36	37	35	51
1	40	0.52	80	37	38	40	48
1	45	0.59	90	31	32	32	36
1	50	0.65	100	33	32	34	33
1	55	0.72	110	35	38	36	33

Table.5 Analysis of variance for filling efficiency based on cell size and peripheral speed

Source	Type III Sum of Squares	df	Mean square	F	Sig.
Corrected Model	7041.400 ^a	19	370.600	37.88	.000
Intercept	102011.267	1	102011.267	10374.027	.000
C	2160.000	1	2160.000	219.661	.000**
S	4728.067	9	525.341	53.424	.000**
C * S	153.333	9	17.037	1.733	.113 NS
Error	393.333	40	9.833		
Total	109446.000	60			
Corrected Total	7434.733	59			

**Significant at 1% probability level

Fig.1 Orthographic and isometric views of the fluted roller metering mechanisms with Dimensions (mm)

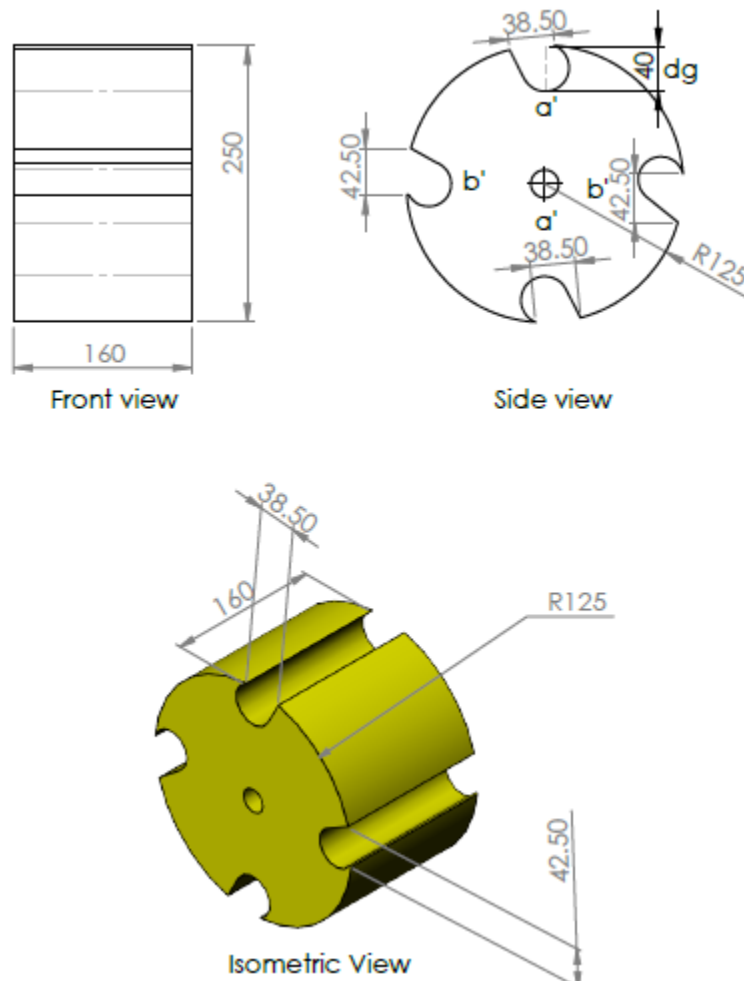
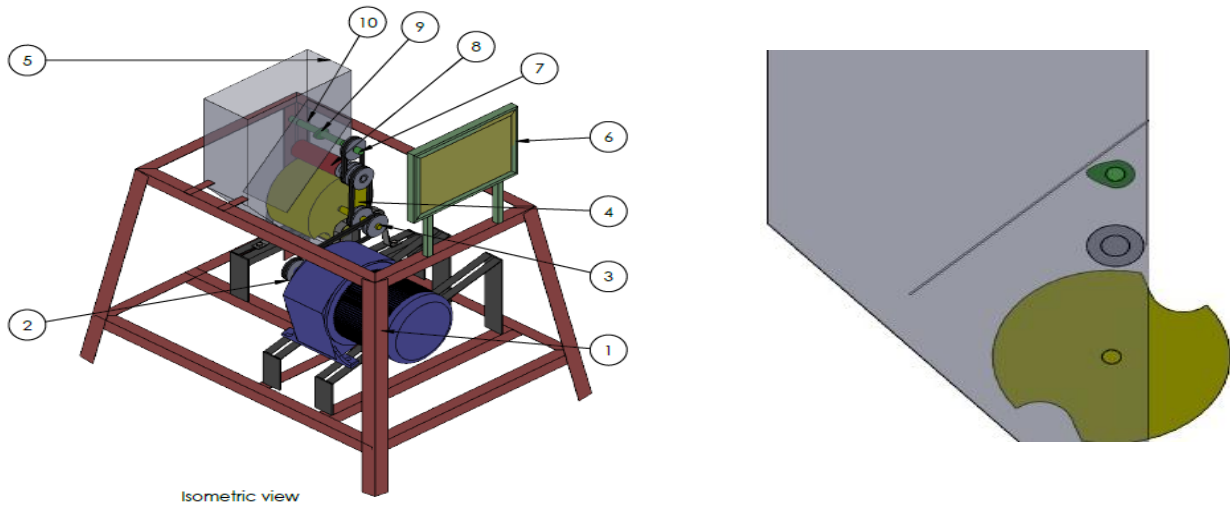

Fig.2 Isometric view of the complete cassava metering test rig



Main frame 2. Varible speed drive motor 3.Metering Shaft 4.Meterin Drum 5.Hopper
6. Speed control board 7.Camshaft 8.Foam Roller 9.Cam 10.Agitation feed trough

Fig.3 Laboratory model of cassava metering test rig



Fig.4 Comparison of filling efficiency of different cell sizes

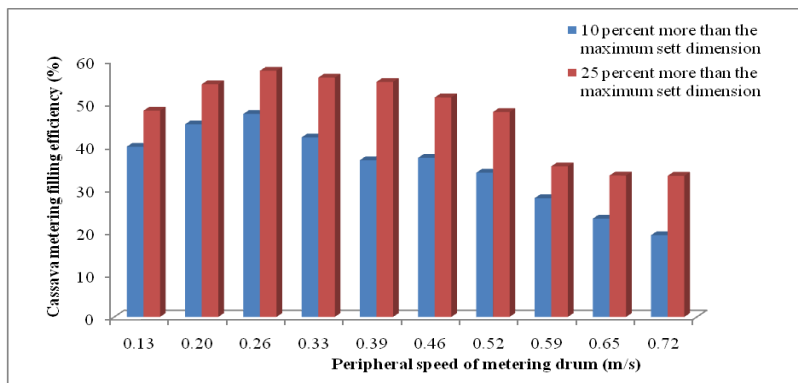

The laboratory results were statistically analyzed with SPSS version 25 for assessing the effect of the variables (cell size, peripheral speed of metering disc). The main effect of cell size and peripheral speed were highly significant ($P < 0.01$) at 1 % probability level. However the interaction of the cell size with the peripheral speed of metering flute was not significant (Table 3–5).

In conclusion, filling efficiency was increased from initial selected speed range to certain level (0.13 to 0.26m/s) and then filling efficiency decreased with increased peripheral speed of fluted roller. The maximum filling efficiency obtained was 58 % at peripheral speed of 0.26 m/s and cell size of 42.50 mm is important for designing fluted roller metering mechanism for cassava sett planter.

References

- Ahmadi, E., H.R. Ghassemzadeh, M. Moghaddam and Kim, K.U. 2008. Development of a precision seed drill for oilseed rape. *Turkish Journal of Agriculture and Forestry*, 32(5), pp.451-458
- Boydas, M.G and Turgut, N. 2007. Effect of vibration, roller design, and seed rates on the seed flow evenness of a studded feed roller. *Applied Engineering in Agriculture*. 23: 413-418.
- Farooq, M., S.I. Ahmad and Majid, A. 1992. Developments in mechanical planting of sugarcane. *Agricultural Mechanical in Asia, Africa and Latin America*, 23(1), pp.29-32.
- Odigboh, E.U. 1978. A two-row automatic cassava cuttings planter: Development, design and prototype construction. *Journal of Agricultural Engineering Research*, 23(2), pp.109-116.
- Pandi, M.D., D. Asokan, J. J. Gunasekar, and Kannan, V. 2017. Influence of Physical properties of Cassava Setts on Co-Efficient of Static Friction. *International Journal of Agriculture Sciences*, 9(48), pp.-4806-4809.
- Ryu, I. H and Kim, K.U. 1998. "Design of roller type metering device for precision planting." *Transactions of the ASAE* 41, no. 4 (1998): 923.
- Varmudy, V. 2014. Cassava cultivation and export: vast scope in India.

How to cite this article:

Dinesh Pandi, M., D. Asokan, J. John Gunasekar and Vallal Kannan, S. 2019. Assessing Suitability of Fluted Roller Metering Mechanism for Cassava Setts Planter. *Int.J.Curr.Microbiol.App.Sci*. 8(05): 1951-1957. doi: <https://doi.org/10.20546/ijcmas.2019.805.226>